

**STRETCH &
CHALLENGE!**

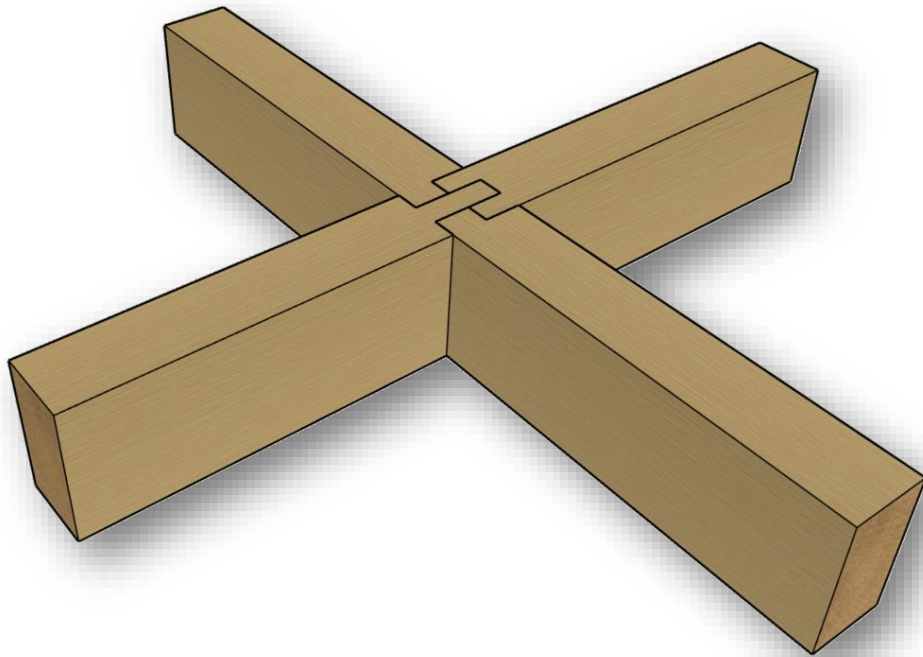
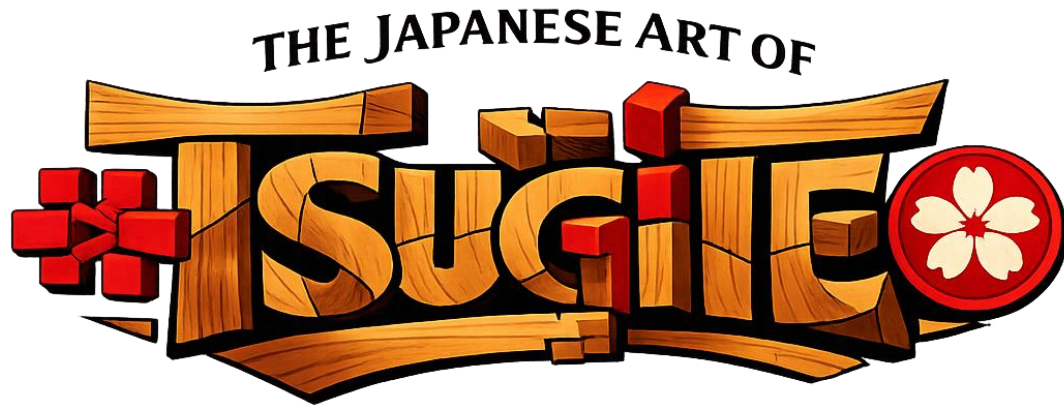

S&C Code: S&C002

S&C Type: Individual

S&C Title: The Japanese Art of Tsugite.

Rating: Medium/Difficult



LCB

STRETCH & CHALLENGE!



This end-of-year Stretch & Challenge event is designed to push your carpentry and joinery skills further than ever before. Throughout the course you've built confidence with tools, techniques, and teamwork — now it's time to put those abilities to the test in a series of fun, hands-on challenges.

You'll work both individually and as part of a team to produce accurate joints, solve practical problems, and demonstrate the craftsmanship you've developed this year. Each task is designed to stretch your precision, creativity, communication, and professional standards, giving you a taste of the expectations found in real workshop environments.

This is your chance to show what you can do, challenge yourself, and take pride in the progress you've made. Let's see your best work.

AIM:

The aim of this activity is to challenge learners to apply precision, patience, and advanced hand-tool skills by constructing a traditional Japanese *tsugite* joint. This task pushes learners beyond standard UK joinery joints, encouraging them to explore global craftsmanship, develop fine motor accuracy, and demonstrate professional behaviours under controlled time pressure.

LEARNING OBJECTIVES:

By the end of this activity, learners will be able to:

- Identify the key features and purpose of a Japanese *tsugite* joint
- Accurately mark out complex interlocking shapes using datum edges and reference lines
- Use hand tools with precision to achieve tight tolerances and clean internal cuts
- Demonstrate problem-solving when refining fit, alignment, and joint engagement
- Work independently and safely while producing a medium–hard difficulty joint
- Evaluate the quality of their finished joint against professional standards

ACTIVITY OVERVIEW:

Learners will construct a Japanese *tsugite* joint (interlocking timber joint) using prepared stock. The joint requires careful planning, accurate marking out, and controlled cutting to achieve a seamless fit. This activity is designed as a **competition-style stretch & challenge**, where learners aim to produce the cleanest, most accurate joint within the allotted time.

The task blends traditional craftsmanship with modern workshop expectations, giving learners a unique opportunity to explore a culturally significant woodworking technique while developing advanced joinery skills.

WHY?:

This activity strengthens:

- **Fine motor control** through precise chisel and saw work
- **Spatial awareness** by visualising interlocking components
- **Measurement accuracy** using datum edges, gauges, and reference lines
- **Patience and resilience** when refining tight-tolerance joints
- **Cultural awareness** by exploring Japanese joinery traditions
- **Professional behaviours** such as tool care, safe working, and pride in craftsmanship

It also prepares learners for Level 2 progression by exposing them to more complex joinery challenges.

STUDENT INSTRUCTIONS:

1. Collect your timber pieces and check they are square, true, and free from defects.
2. Study the example *tsugite* joint diagram and identify the interlocking features.
3. Mark out your joint using a sharp pencil, marking gauge, and datum edges.
4. Double-check all measurements before cutting — accuracy is essential.
5. Use a tenon saw and chisels to remove waste material carefully.
6. Test the fit regularly and refine using paring cuts.
7. Aim for a clean, tight, seamless fit with no gaps or tear-out.
8. Present your finished joint for assessment and comparison.

LECTURER INSTRUCTIONS:

- Introduce the cultural background of *tsugite* and show visual examples.
- Demonstrate the marking-out process slowly, emphasising datum control.
- Model safe and precise chisel techniques for internal waste removal.
- Circulate to support learners with measurement checks and tool selection.
- Encourage learners to test-fit frequently and refine gradually.
- Facilitate the competition element by displaying finished joints for comparison.
- Provide constructive feedback focusing on accuracy, cleanliness, and craftsmanship.

SCAFFOLDING STRATEGY:

(SEND-friendly & mixed-ability)

- Provide **pre-drawn marking-out templates** for learners who need support.
- Offer **step-by-step diagrams** showing each stage of the joint.
- Supply **partially pre-cut stock** for learners who struggle with sawing accuracy.
- Use **visual overlays** showing correct vs incorrect marking out.
- Provide **practice blocks** for learners to rehearse chisel control before starting.
- Allow **paired working** for learners who benefit from collaborative support.
- Offer **tool-specific mini-tutorials** (e.g., how to pare cleanly with a chisel).

DIFFERENTIATION STRATEGIES:

For learners needing support:

- Simplify the joint by reducing the number of interlocking features
- Allow extended time or chunk the task into smaller milestones
- Provide guided marking-out sheets
- Use thicker stock to make the joint easier to visualise

For learners ready for challenge:

- Introduce a more complex *tsugite* variation
- Add a time-based competitive element
- Require learners to produce a technical sketch of the joint
- Ask learners to explain the cultural significance of Japanese joinery
- Introduce tolerance targets (e.g., <1mm gap)

ASSESSMENT OPPORTUNITIES:

- **Marking out accuracy** (alignment, clarity, correct use of datum edges)
- **Cutting precision** (clean saw lines, minimal tear-out)
- **Chisel control** (smooth internal faces, no over-cutting)
- **Joint fit** (tightness, alignment, engagement)
- **Workmanship quality** (finish, tool care, safe working)
- **Reflection** (learner self-assessment or peer comparison)

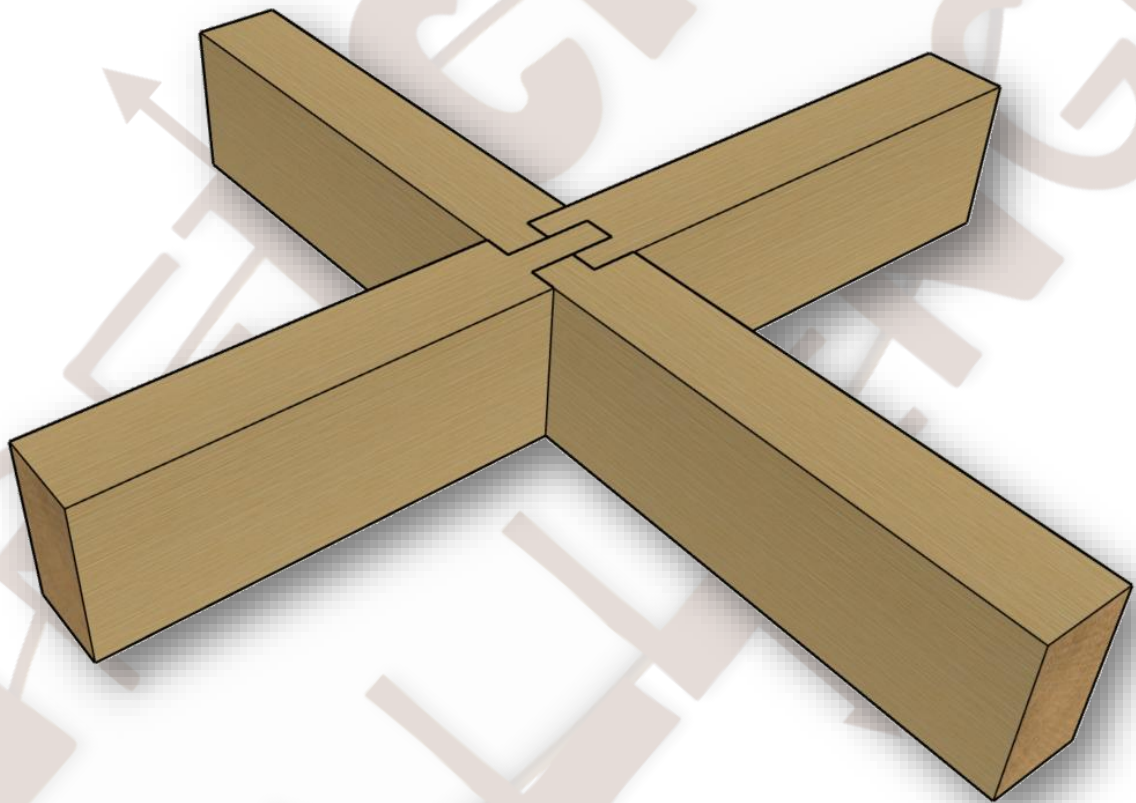

S&C002: The Japanese Art of Tsugite

 STRETCH & CHALLENGE!	Stretch & Challenge.
S&C001	Leeds College of Building
Date 20/04/2026.	Scale: none.
	Drawing No.001.
	James Rix.

Exploded Projection.

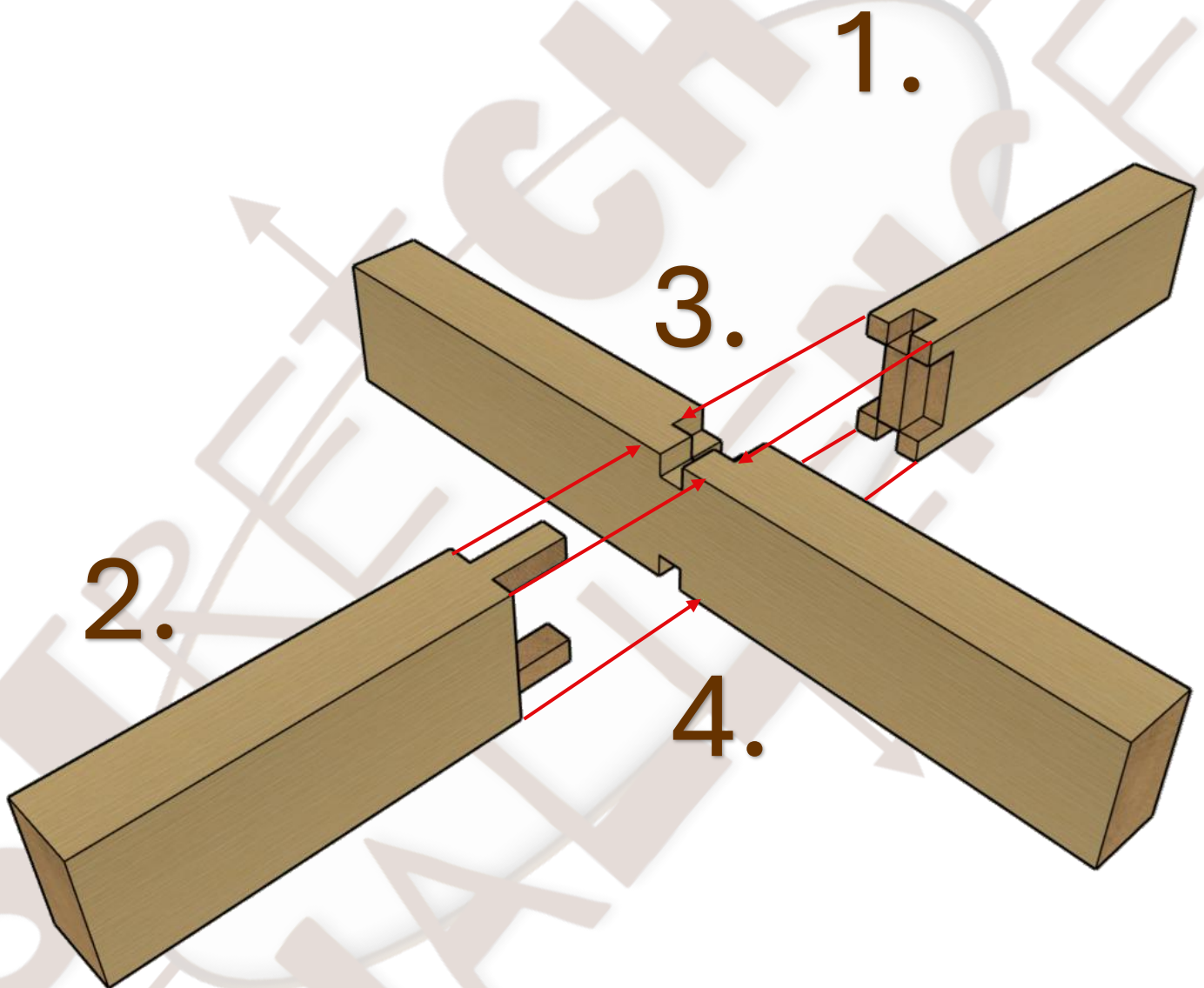

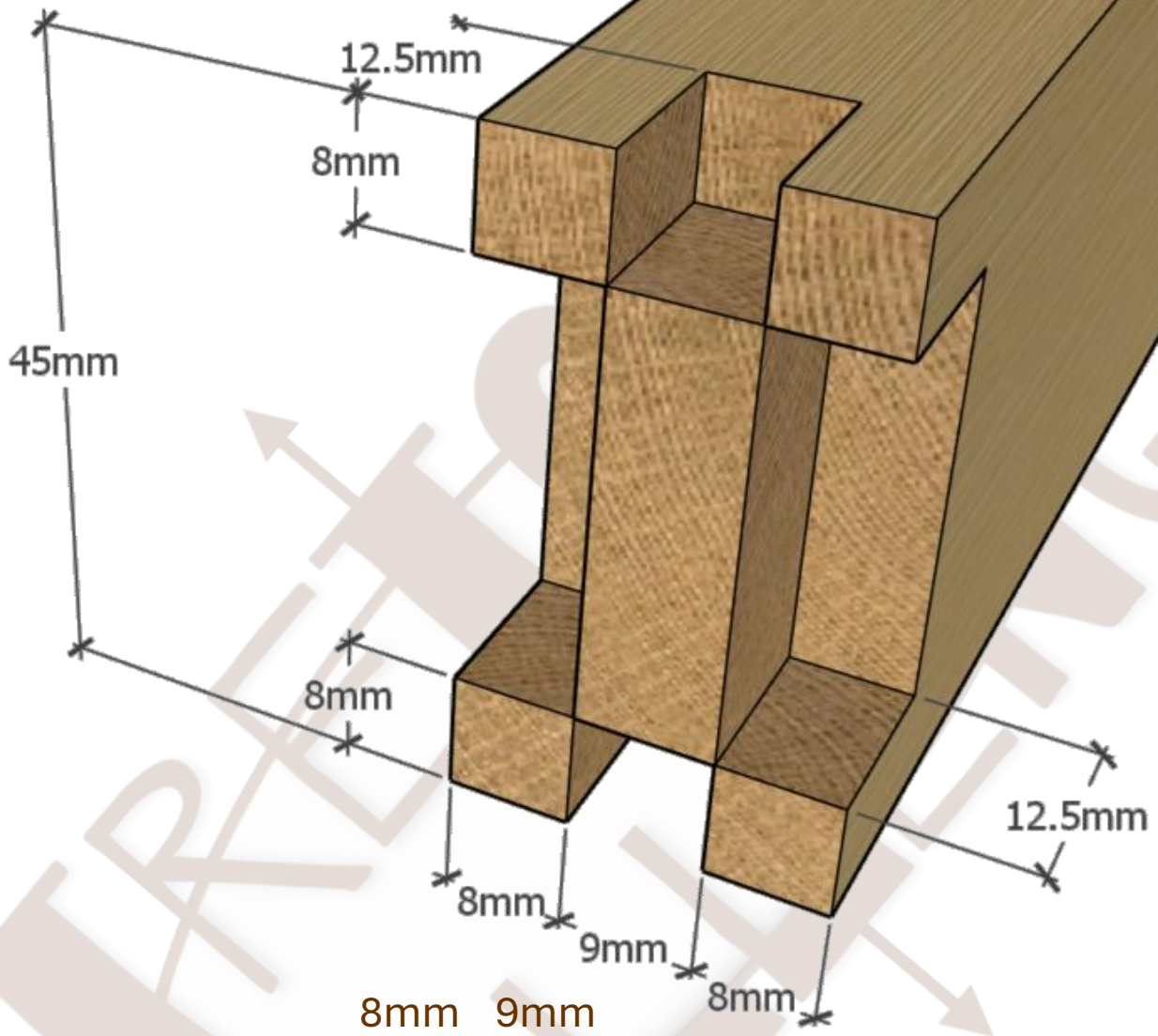

8mm

8mm



LCB

1.

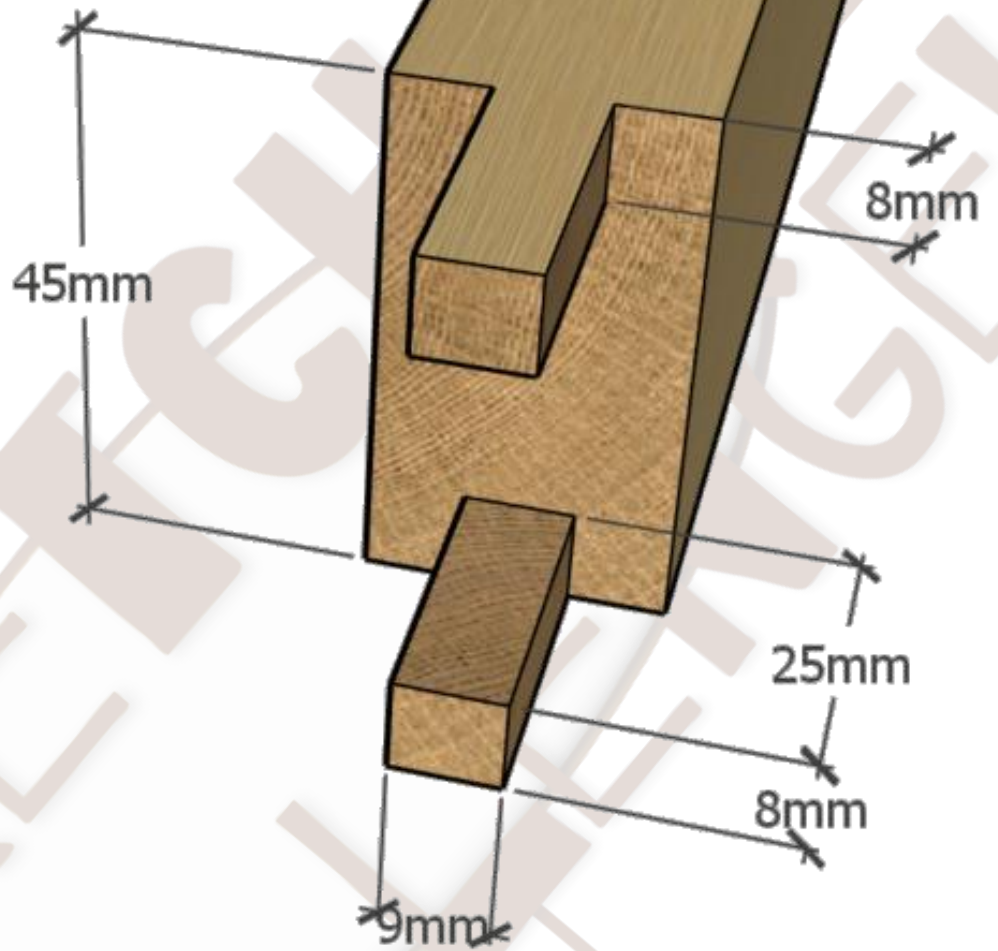

8mm 9mm

8mm

8mm



LCB

2.

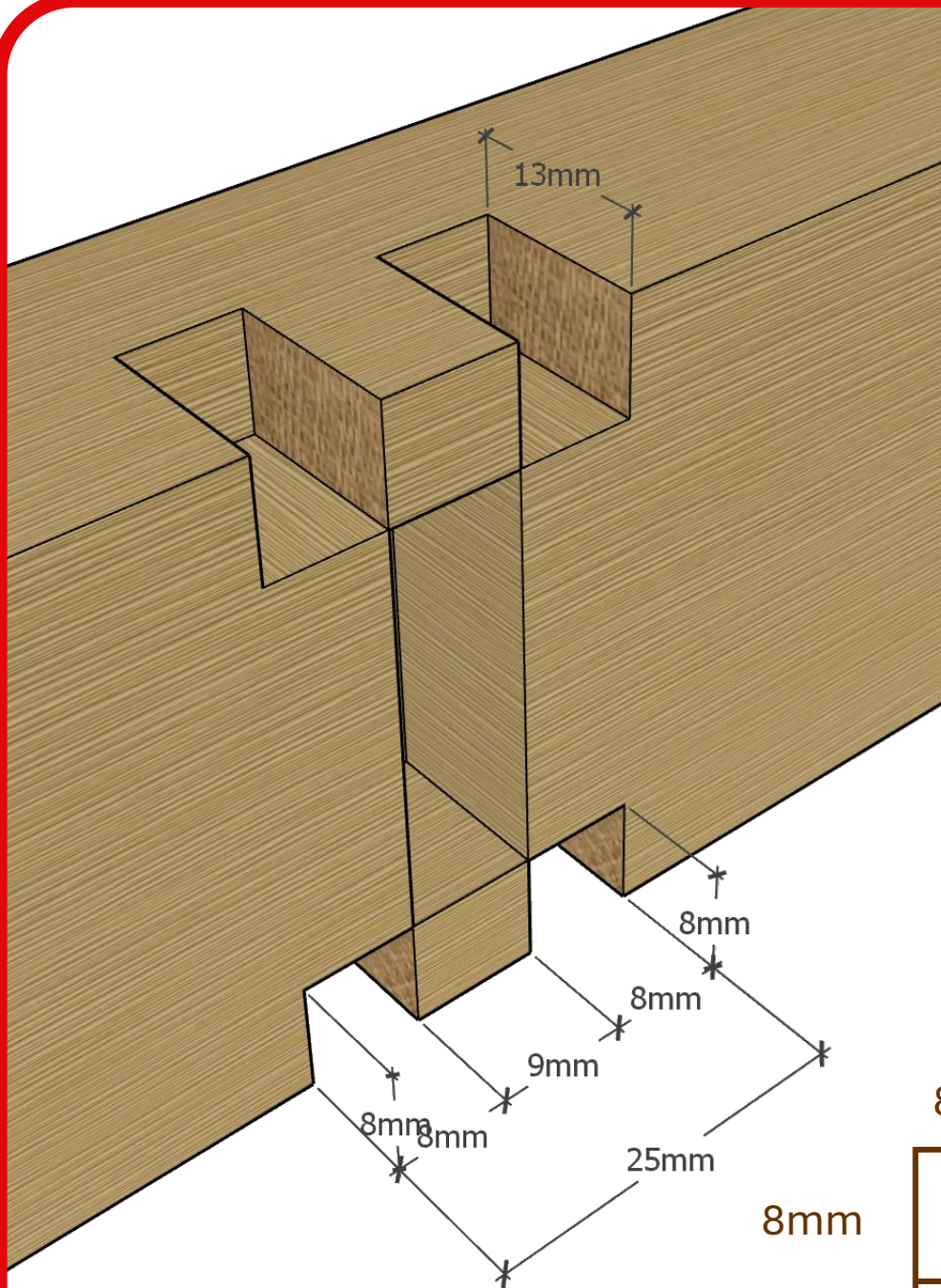

8mm 9mm

8mm

8mm

3.



LCB

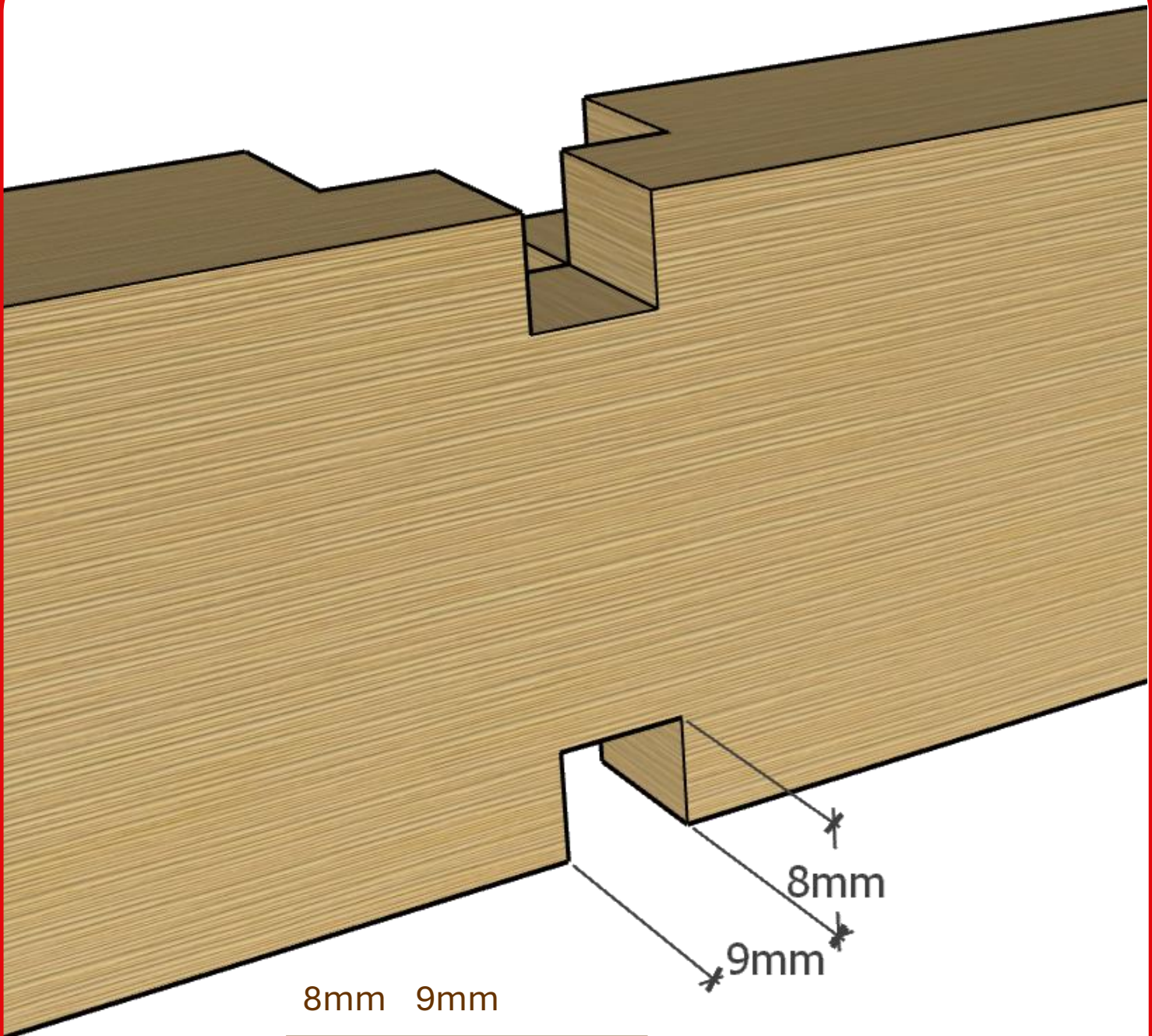

8mm 9mm

8mm
9mm

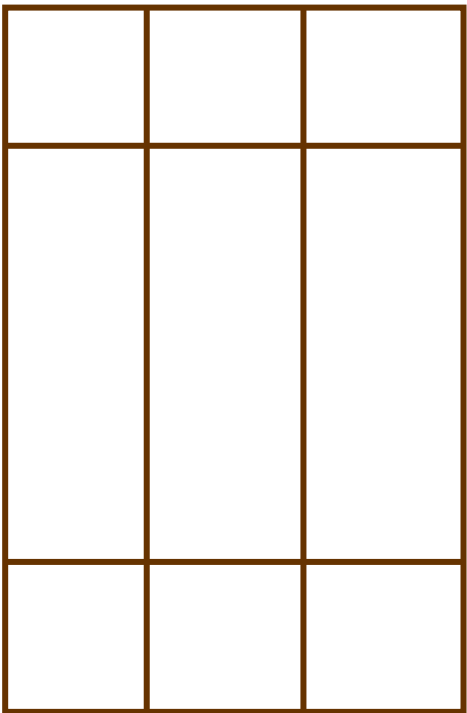

8mm

8mm

4.



LCB