

STRETCH & CHALLENGE!

S&C Code: S&C001

S&C Type: Team

S&C Title: 4 Joint Relay Challenge.

Rating: Easy/Medium

This end-of-year Stretch & Challenge event is designed to push your carpentry and joinery skills further than ever before. Throughout the course you've built confidence with tools, techniques, and teamwork — now it's time to put those abilities to the test in a series of fun, hands-on challenges.

You'll work both individually and as part of a team to produce accurate joints, solve practical problems, and demonstrate the craftsmanship you've developed this year. Each task is designed to stretch your precision, creativity, communication, and professional standards, giving you a taste of the expectations found in real workshop environments.

This is your chance to show what you can do, challenge yourself, and take pride in the progress you've made.

Let's see your best work.

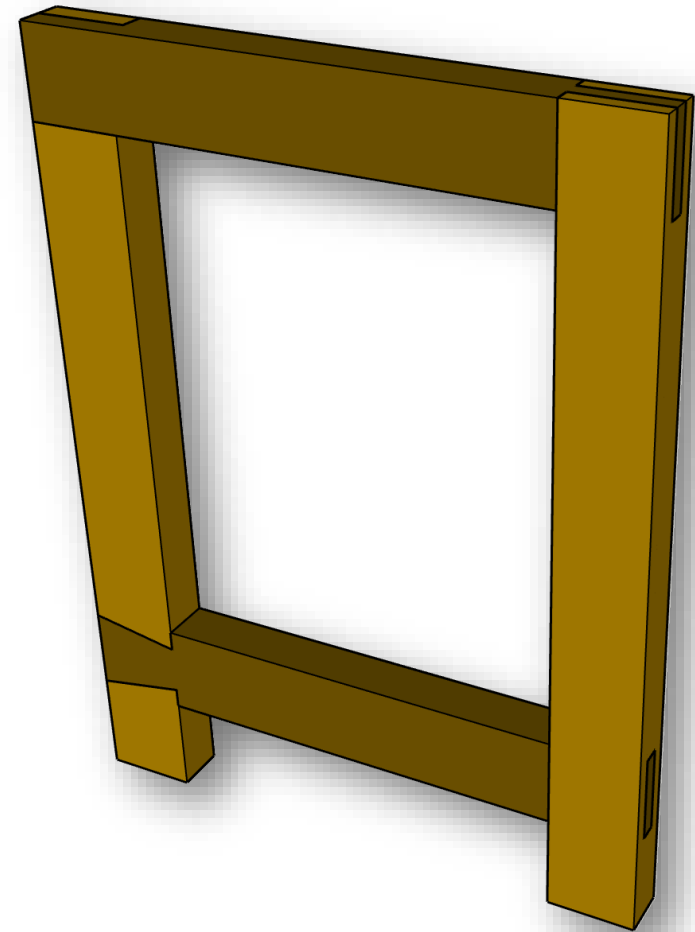

AIM:

The aim of the 4-Joint Frame Relay is to push learners beyond routine workshop tasks and challenge them to apply their developing carpentry and joinery skills in a coordinated, high-accuracy team project. This activity is designed to strengthen precision, confidence, and craftsmanship by requiring each learner to take full responsibility for producing one high-quality joint that must integrate seamlessly into a shared frame.

Through this challenge, learners will deepen their understanding of measurement accuracy, datum control, and joint compatibility while experiencing the real-world pressures of sequencing, communication, and collaborative problem-solving. The task encourages learners to take pride in their workmanship, demonstrate professional behaviours, and showcase the progress they have made throughout the year. Ultimately, the activity aims to stretch their technical ability, raise expectations, and prepare them for the higher-level demands of future carpentry and joinery work.

LEARNING OBJECTIVES:

By the end of this challenge, learners will be able to:

- Mark out and cut a selected woodworking joint with improved precision.
- Work collaboratively to produce a multi-joint frame.
- Apply sequencing, communication, and problem-solving skills under time pressure.
- Evaluate the accuracy, fit, and finish of joints against set tolerances.

ACTIVITY OVERVIEW:

Teams of four will construct a small rectangular frame. The joints used in this frame are:

1. Corner Halving Joint
2. Corner Bridle Joint
3. Through Mortice & Tenon Joint
4. Dovetail Halving Joint

The frame must assemble cleanly, sit flat, and remain square. Teams must coordinate marking out, datum edges, and measurements to ensure all joints align.

Marking Criteria can be found in this booklet.

WHY?:

Why this activity stretches and challenges learners.

The 4-Joint Frame Relay pushes learners beyond routine workshop practice by placing them in a situation where accuracy, teamwork, and responsibility directly affect the success of the final product. Unlike isolated joint-making tasks, this challenge requires each learner to produce a joint that must integrate perfectly with three others, demanding a higher level of precision and consistency than they have previously been exposed to.

Learners must work from shared measurements, agree on datum edges, and communicate clearly to ensure that all components align. This mirrors real-world joinery environments where poor communication or inaccurate marking out can compromise an entire build. The activity also introduces time pressure, sequencing, and the need for problem-solving when joints don't initially fit as expected.

By taking ownership of one joint within a collaborative frame, learners experience the professional expectation of producing work that others rely on. This raises the stakes, encourages pride in workmanship, and challenges them to apply their skills with greater care and confidence. Ultimately, the activity stretches their technical ability, strengthens their understanding of joint compatibility, and develops the teamwork and resilience needed for progression in the trade.

TEAM INSTRUCTIONS:

- 1. Form teams.**
 - This is to be determined by your lecturer
- 2. Assign a team structure.**
 - Assign a team captain
 - Assign each of the team members the joints they are going to be responsible for.
 - Assign a team name.
- 3. Study your task.**
 - Know your task
 - Know your terminology
 - Know your tools and equipment
- 4. Strategise**
 - Is one person quicker at achieving a task over another?
 - Are you going to sacrifice time over quality? Or quality over time?
 - Are you being inclusive and using differentiation strategies
 - Who goes first? And why? Will you stick to an order, or will it depend on the task?
- 5. Instructions.**
 - Each player has 5 minutes to complete as much of the task as possible.
 - Taking it in turns, once the 5 minutes is up player are to stop what they are doing and allow the next player to take over.
 - Your joint, you're responsibility. Communication is encouraged and paramount when trying to help verbally. Terminology is key to knowing and understanding.
 - Only the player whose time it is may perform any practical tasks
 - The challenge is scored in many ways, mostly via the task tracking sheet but also you will be tracked on your performance as a team and individuals, communication, inclusivity, diversity and British Values will also be looked at.
 - The winning team is the team with the most overall points.

LECTURER INSTRUCTIONS:

Instructions:

Before the activity

- Prepare examples of each joint
- Provide a preprepared S&C record Sheet
- Provide established criteria and points scoring system

During the activity

- Observe communication and sequencing.
- Prompt teams to check datum edges and shared measurements.
- Offer stretch questions:
 - “How will you ensure your joints align?”
 - “What tolerance are you working to?”
 - “Who is checking squareness?”

After the activity

- Facilitate a team reflection:
 - What went well?
 - What caused misalignment?
 - How could communication improve?
- Display the best frames as “Excellence in Craft” examples.

SCAFFOLDING STRATEGY:

- Provide joint templates for lower-confidence learners.
- Offer a “joint practice block” for 5 minutes before starting.
- Use colour-coded team roles (marker, cutter, checker, assembler).
- Provide a laminated “Joint Accuracy Checklist” for each team.

DIFFERENTIATION STRATEGIES:

Support

- Pre-drawn reference lines for learners who struggle with marking out.
- Allow paired marking out for those needing reassurance.
- Provide simplified joints (e.g., halving instead of dovetail).

Stretch

- Add chamfers or decorative shaping.
- Require joints to be flush within ± 0.5 mm - ± 3.0 mm.
- Introduce a time limit for each stage.
- Ask advanced learners to lead team planning.

ASSESSMENT OPPORTUNITIES:

Technical Quality

- Joint fit (tightness, gaps, shoulder accuracy)
- Saw accuracy and chisel control
- Cleanliness of finish
- Squareness of assembled frame

Teamwork

- Communication
- Shared measurement accuracy
- Sequencing and planning
- Problem-solving

Professional Behaviours

- Tool care
- Safe working
- Respectful collaboration

S&C001: 4 Joint Relay Frame

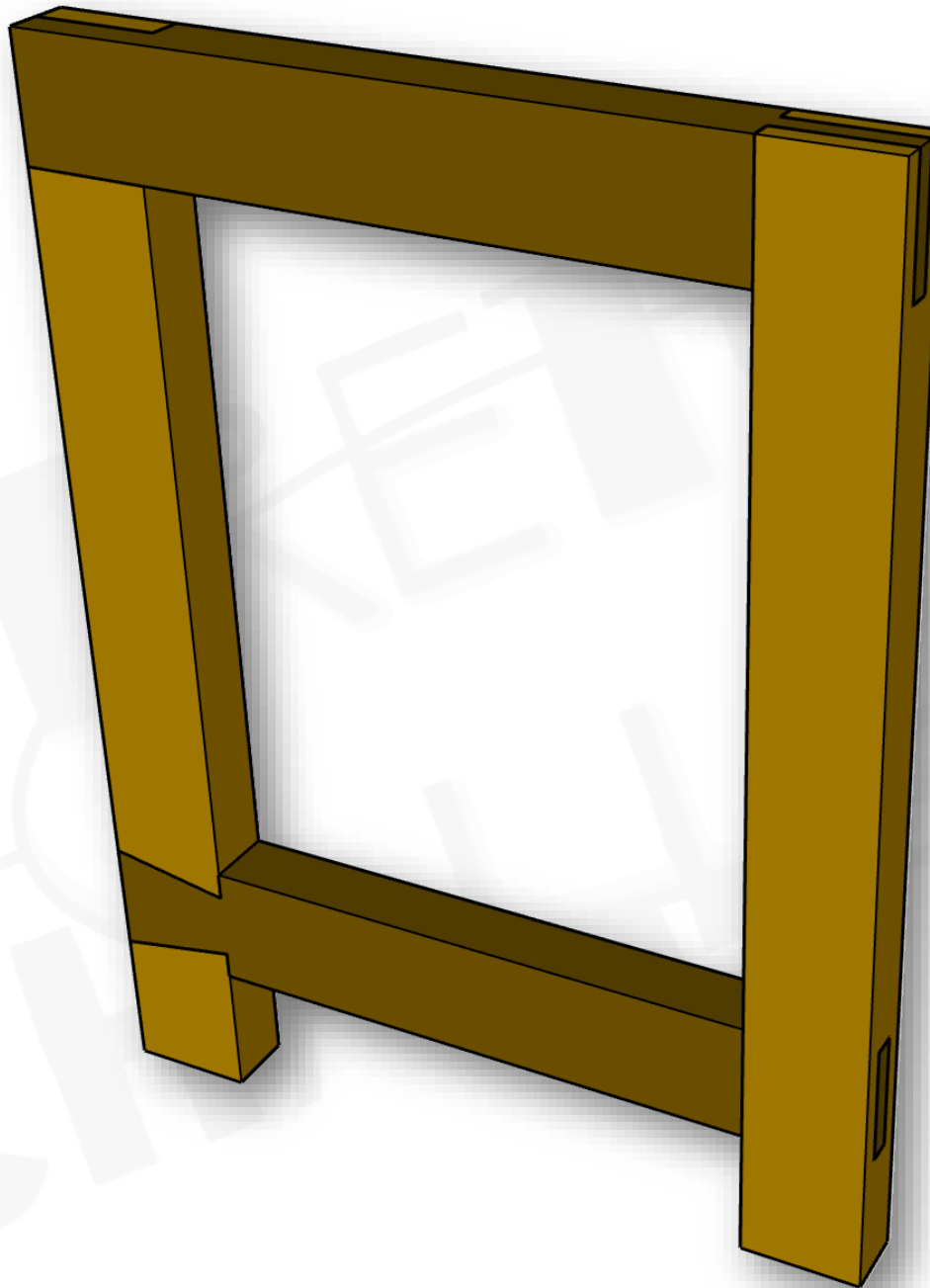

LCB

**STRETCH &
CHALLENGE!**

Stretch & Challenge.

Leeds College
of Building

S&C001

Scale: none.

Drawing No.001.

Date 20/04/2026.

James Rix.



Exploded Projection.

Corner Halving Joint

Corner Bridle Joint

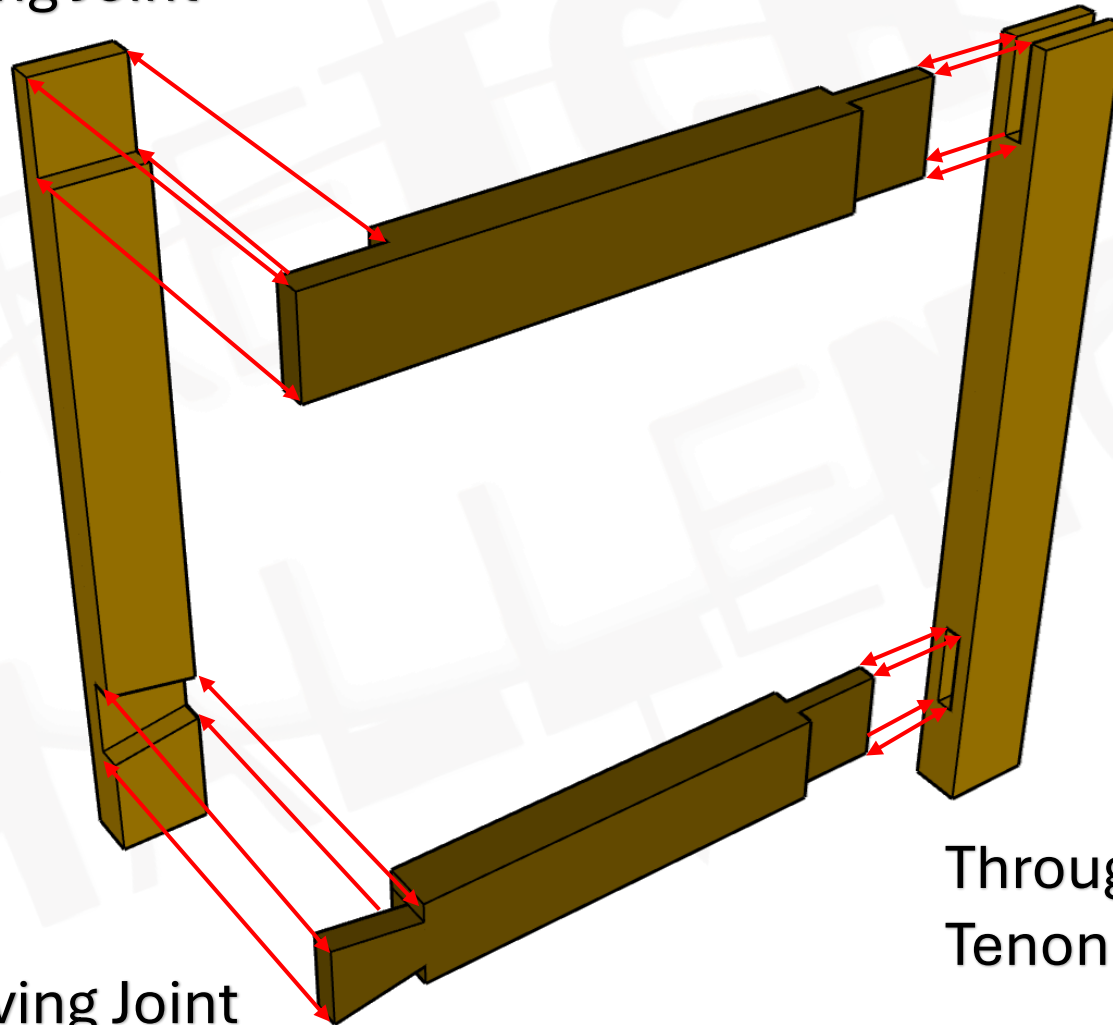

Through Mortice & Tenon Joint

Dovetail Halving Joint

Overall Dimensions:

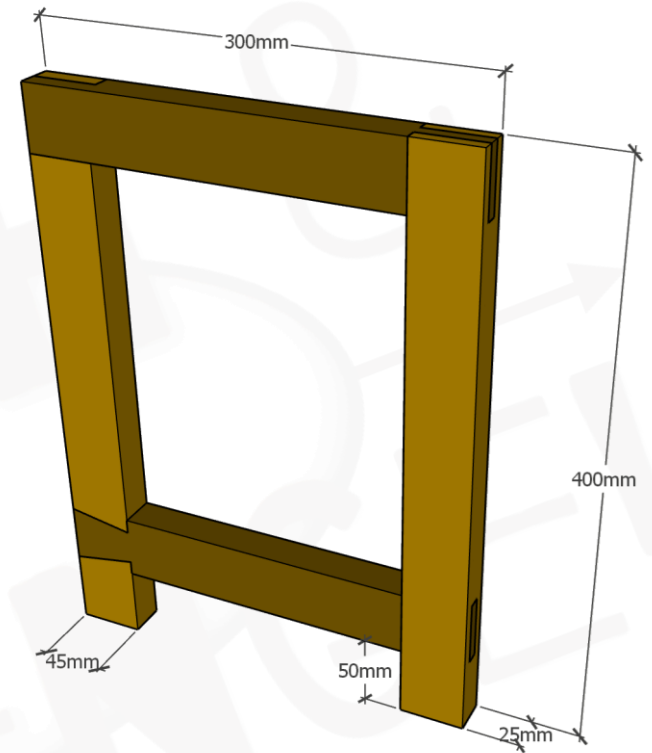
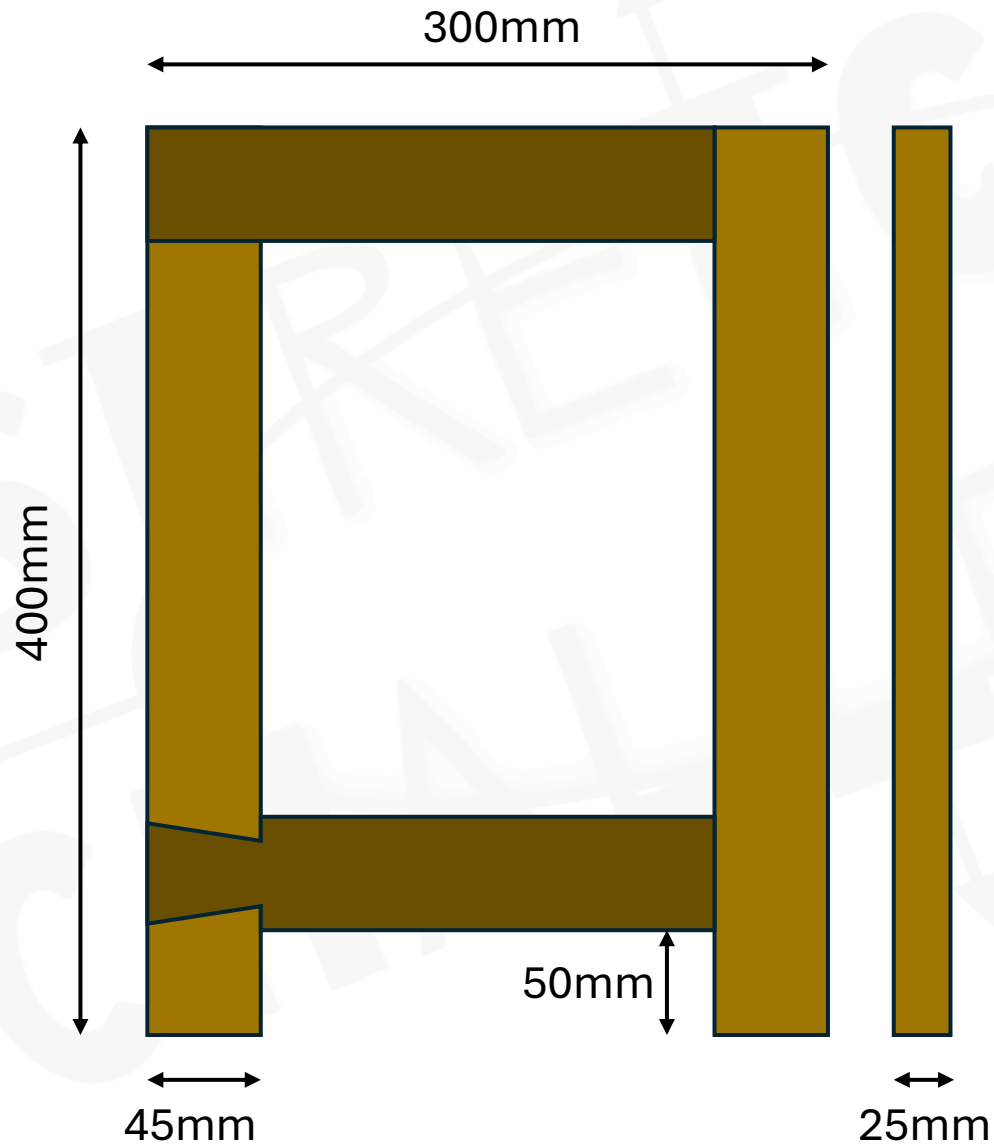

Corner Halving Joint.

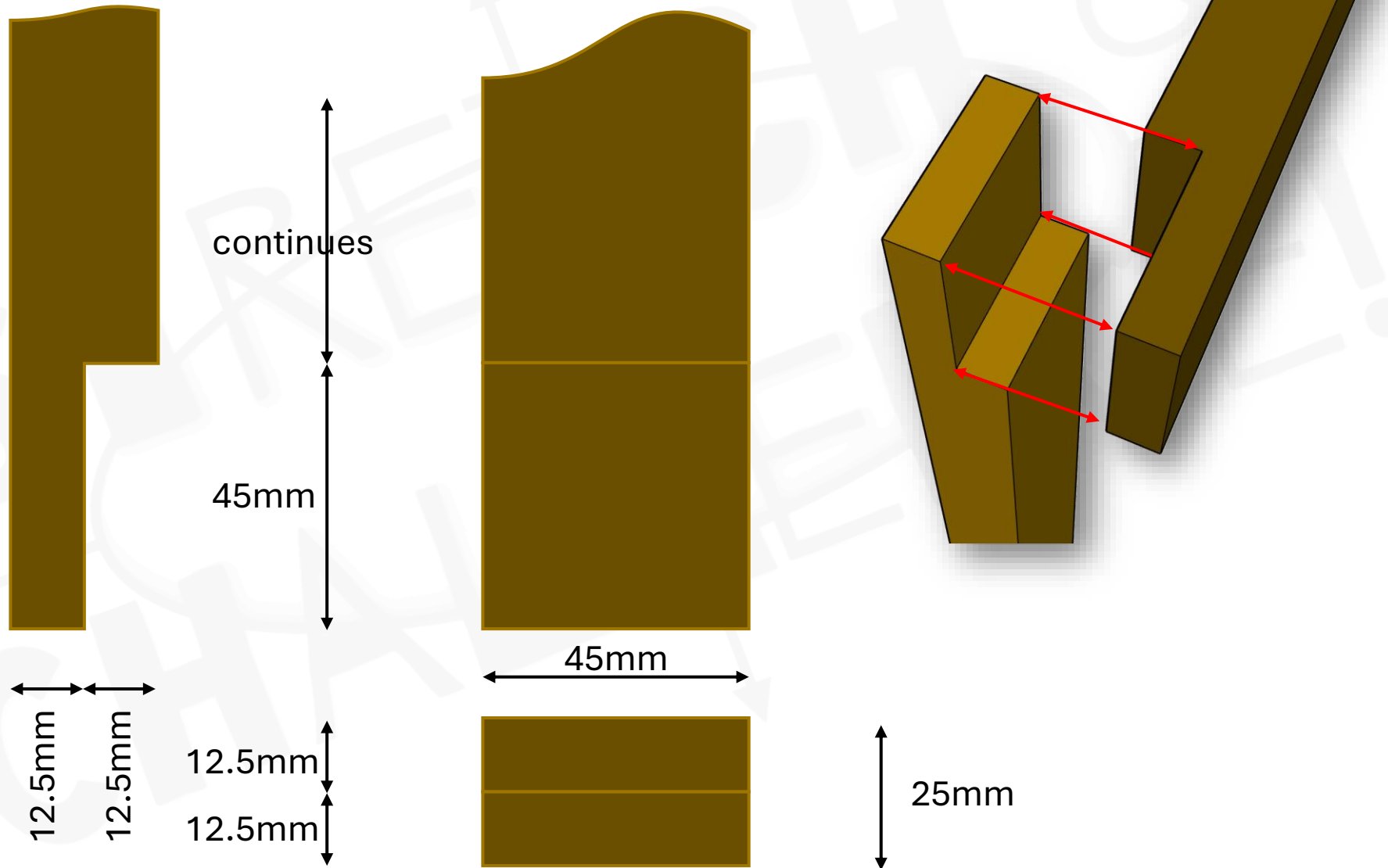

Corner Bridle Joint.

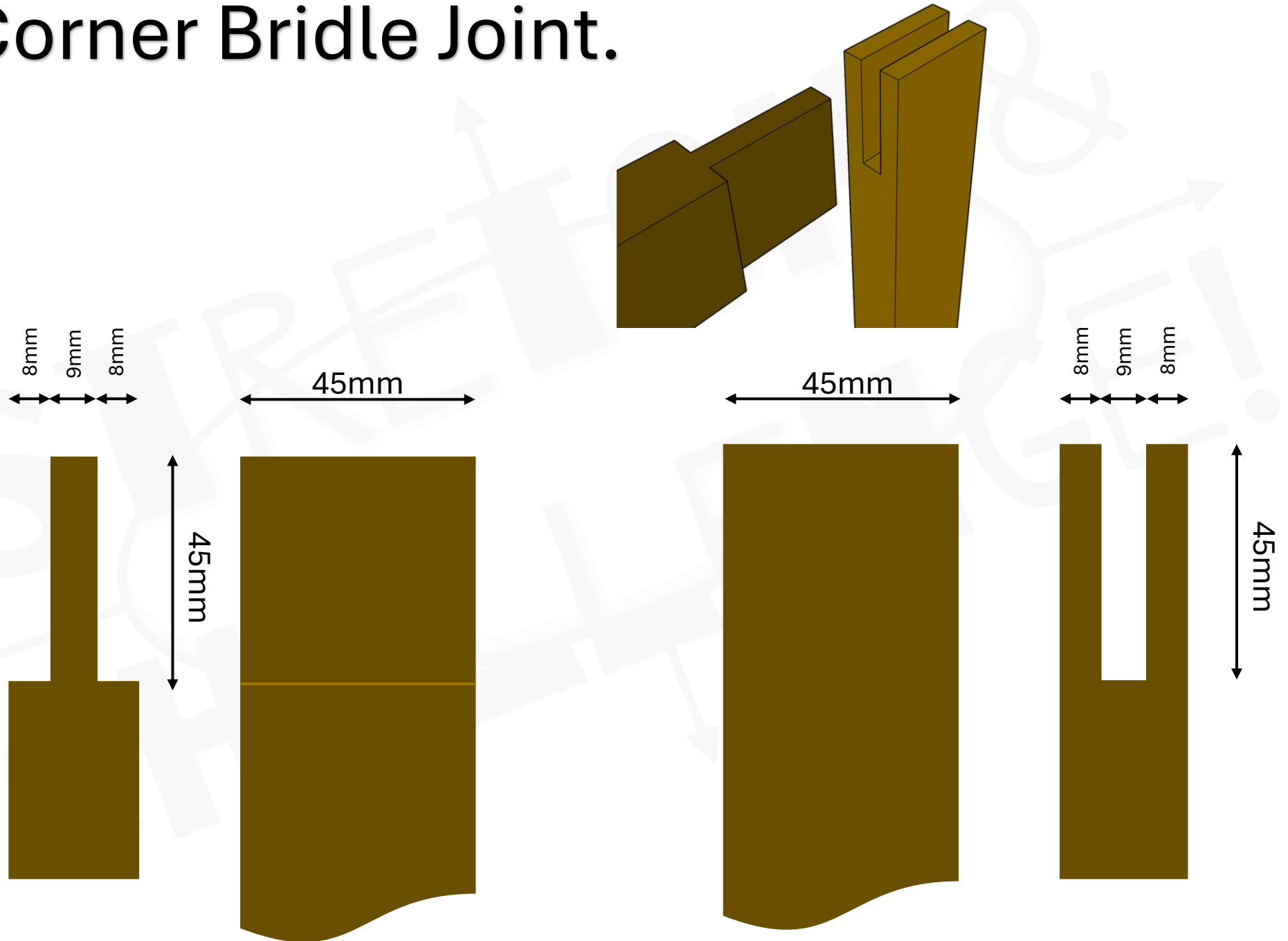

Through Mortice & Tenon Joint.

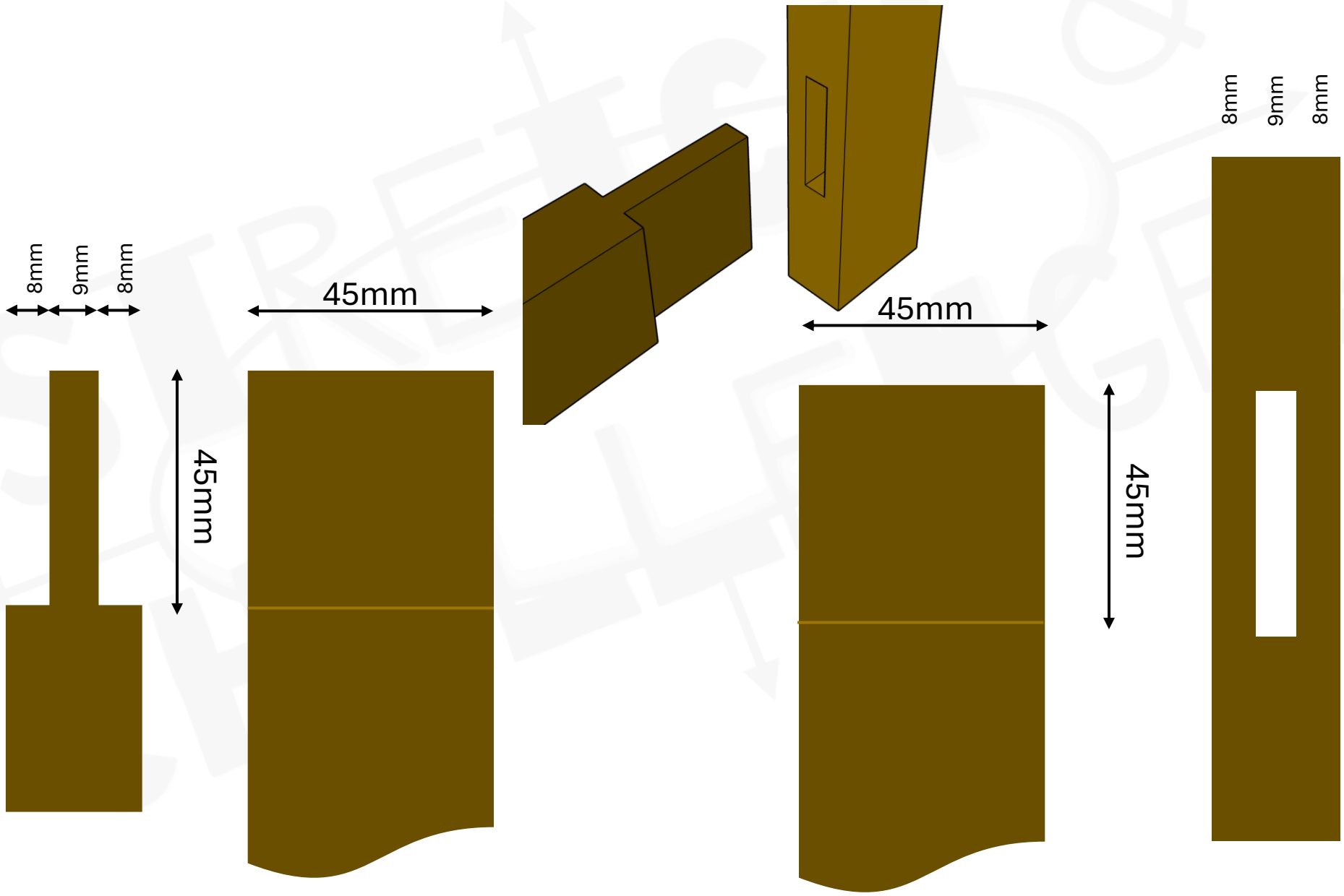

Dovetail Halving Joint.

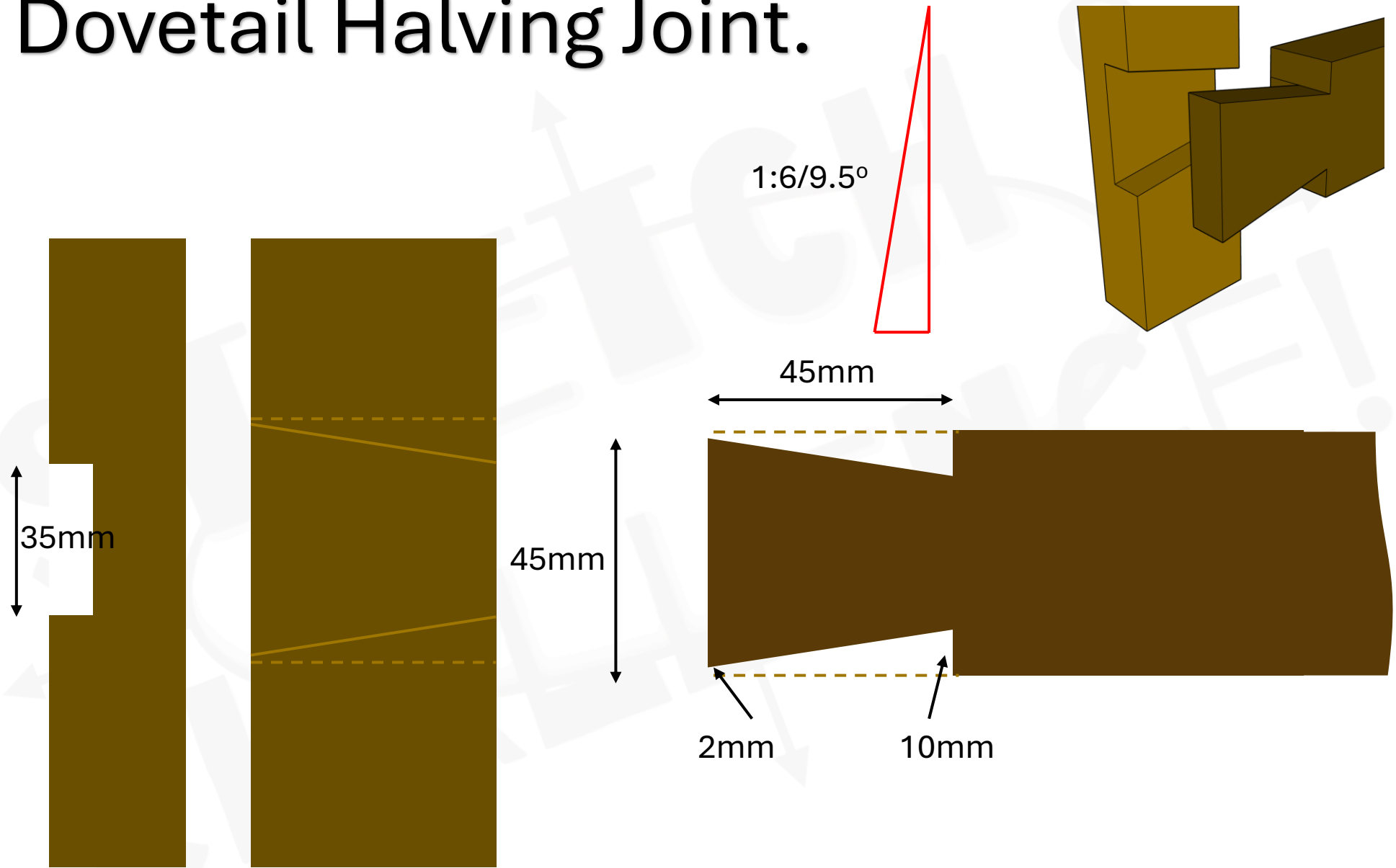

Corner Halving Joint – Joint Template.

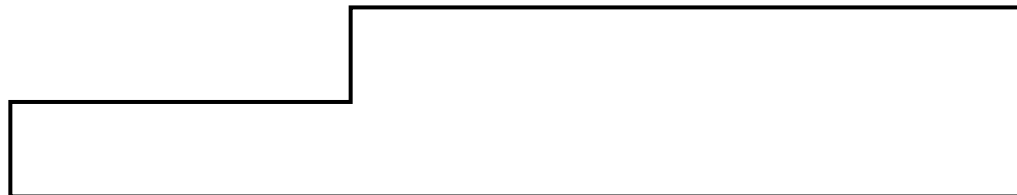

Corner Bridle Joint – Joint Template.

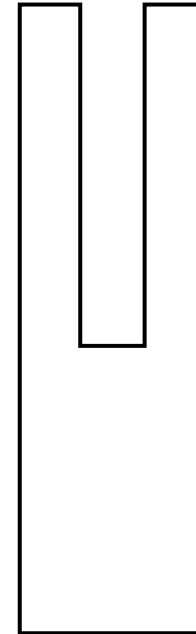
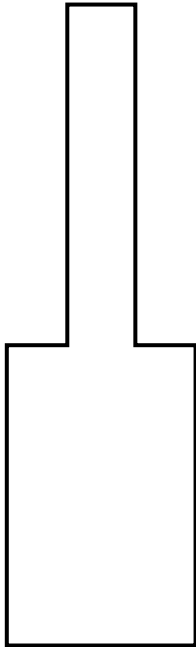

Through Mortice & Tenon Joint – Joint Template.

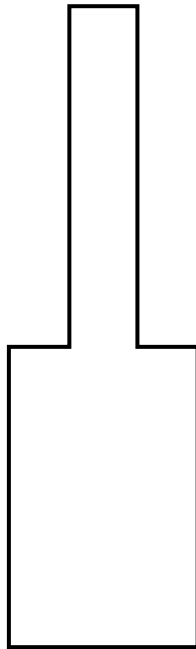

Dovetail Halving Joint – Joint Template.

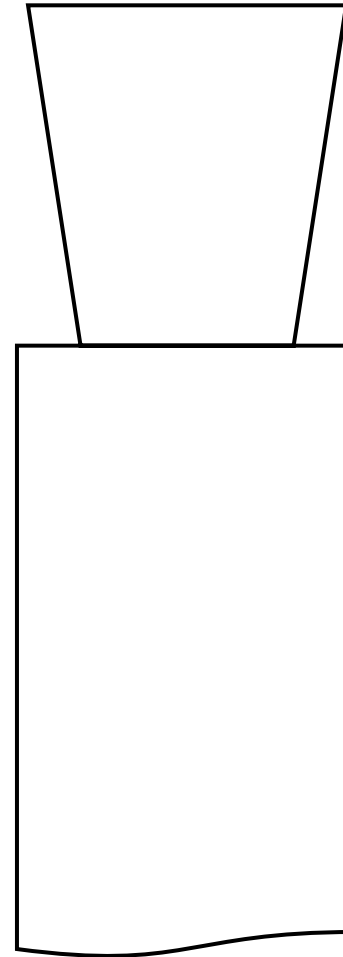

MARKING CRITERIA:

Task	★★★★	★★★☆☆	★★☆☆☆	★☆☆☆☆
Marking Out				
Face side & face edge marked	yes	no		Not used
Lines are sharp, clear and consistent	Good	Medium		Requires Improvement
Lines are within accuracy	1mm	2mm		3mm
Waste clearly identified				
Sawing				
Saw cuts with no drifting	1mm	2mm		3mm
Cuts are straight and vertical	1mm	2mm		3mm
Accuracy of cutting to lines	1mm	2mm		3mm
Tear out & Bruising				
Chisel Work				
Cuts are controlled and follow marked lines	1mm	2mm		3mm
Shoulders are crisp and square	Yes	No		
Depth is consistent	Yes	No		
Waste removed cleanly				
Joint Fit				
Joints fit together without force	1mm	2mm		3mm
No visible gaps when assembled	1mm	2mm		3mm
Shoulders are tight and sit flush	1mm	2mm		3mm
Joint sits square when fitted	1mm	2mm		3mm

Task



Surface Quality				
Edges are clean and free from splinters				
No deep tool marks or gouges				
Faces are smooth and consistent				
Arrises are slightly eased				
Behaviours				
Tools used safely and correctly				
Work area kept tidy and safe				
Handled with care				
Good communication throughout				

STRETCH & CHALLENGE!

S&C Code: S&C001

S&C Type: Team

S&C Title: 4 Joint Relay Challenge.

Rating: Easy/Medium

This end-of-year Stretch & Challenge event is designed to push your carpentry and joinery skills further than ever before. Throughout the course you've built confidence with tools, techniques, and teamwork — now it's time to put those abilities to the test in a series of fun, hands-on challenges.

You'll work both individually and as part of a team to produce accurate joints, solve practical problems, and demonstrate the craftsmanship you've developed this year. Each task is designed to stretch your precision, creativity, communication, and professional standards, giving you a taste of the expectations found in real workshop environments.

This is your chance to show what you can do, challenge yourself, and take pride in the progress you've made.

Let's see your best work.

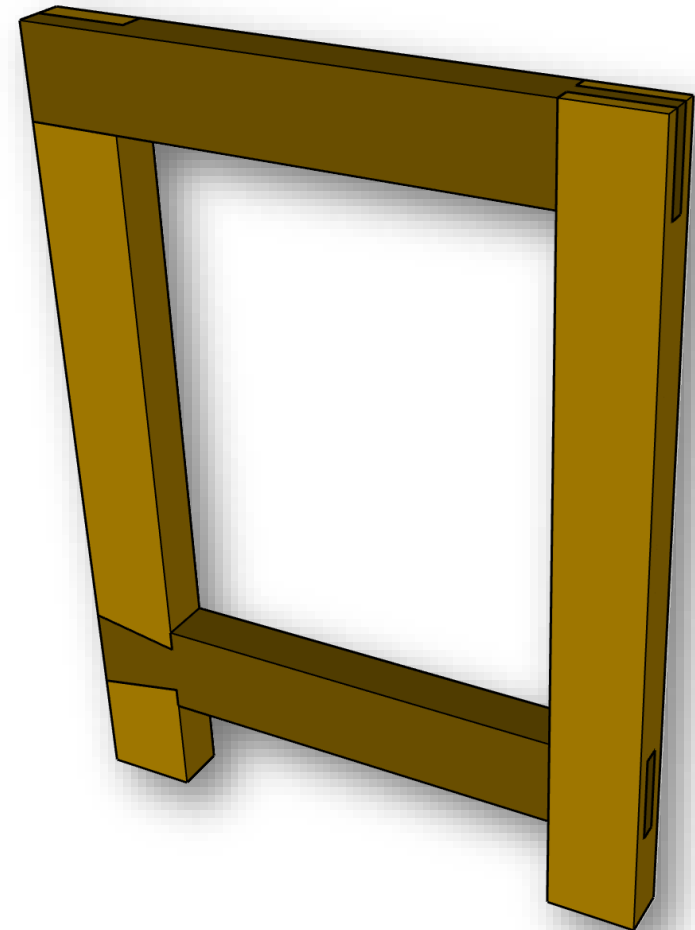

TEAM INSTRUCTIONS:

1. Form teams.

- This is to be determined by your lecturer

2. Assign a team structure.

- Assign a team captain
- Assign each of the team members the joints they are going to be responsible for.
- Assign a team name.

3. Study your task.

- Know your task
- Know your terminology
- Know your tools and equipment

4. Strategise

- Is one person quicker at achieving a task over another?
- Are you going to sacrifice time over quality? Or quality over time?
- Are you being inclusive and using differentiation strategies
- Who goes first? And why? Will you stick to an order, or will it depend on the task?

5. Instructions.

- Each player has 5 minutes to complete as much of the task as possible.
- Taking it in turns, once the 5 minutes is up player are to stop what they are doing and allow the next player to take over.
- Your joint, you're responsibility. Communication is encouraged and paramount when trying to help verbally. Terminology is key to knowing and understanding.
- Only the player whose time it is may perform any practical tasks
- The challenge is scored in many ways, mostly via the task tracking sheet but also you will be tracked on your performance as a team and individuals, communication, inclusivity, diversity and British Values will also be looked at.
- The winning team is the team with the most overall points.

CHECKLIST:

- Ensure each member of the team has a responsibility
- Pick out your wood/materials.
- Know your required stock sizes
- Mark your wood/materials with face side and face edge
- Mark out the joints accurately
- Measure twice, cut once
- Study your Drawings/Specifications
- Write up a cutting list for your challenge
- Mark waste clearly

S&C001: 4 Joint Relay Frame

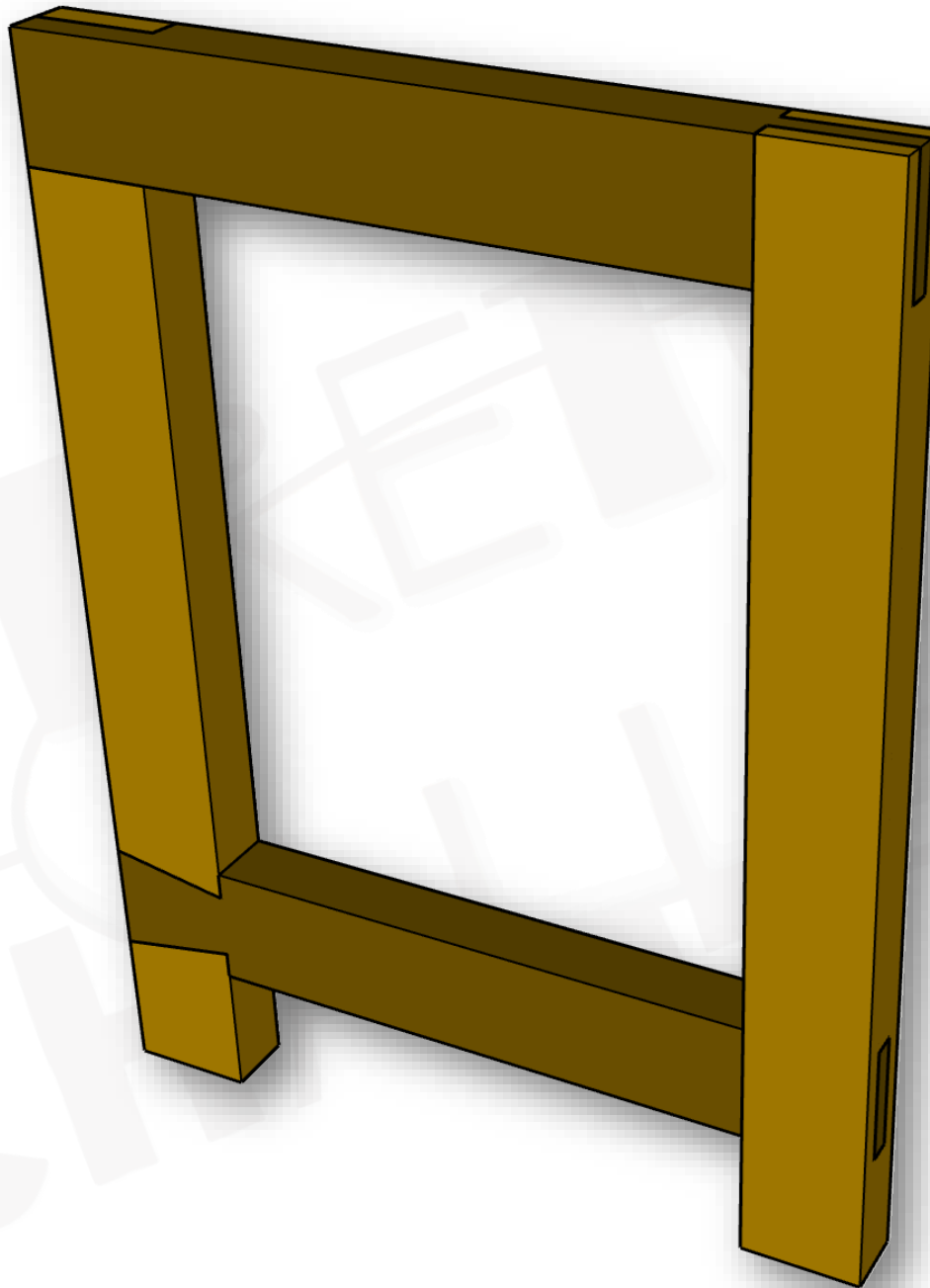

LCB

**STRETCH &
CHALLENGE!**

Stretch & Challenge.

Leeds College
of Building

S&C001

Scale: none.

Drawing No.001.

Date 20/04/2026.

James Rix.



Exploded Projection.

Corner Halving Joint

Corner Bridle Joint

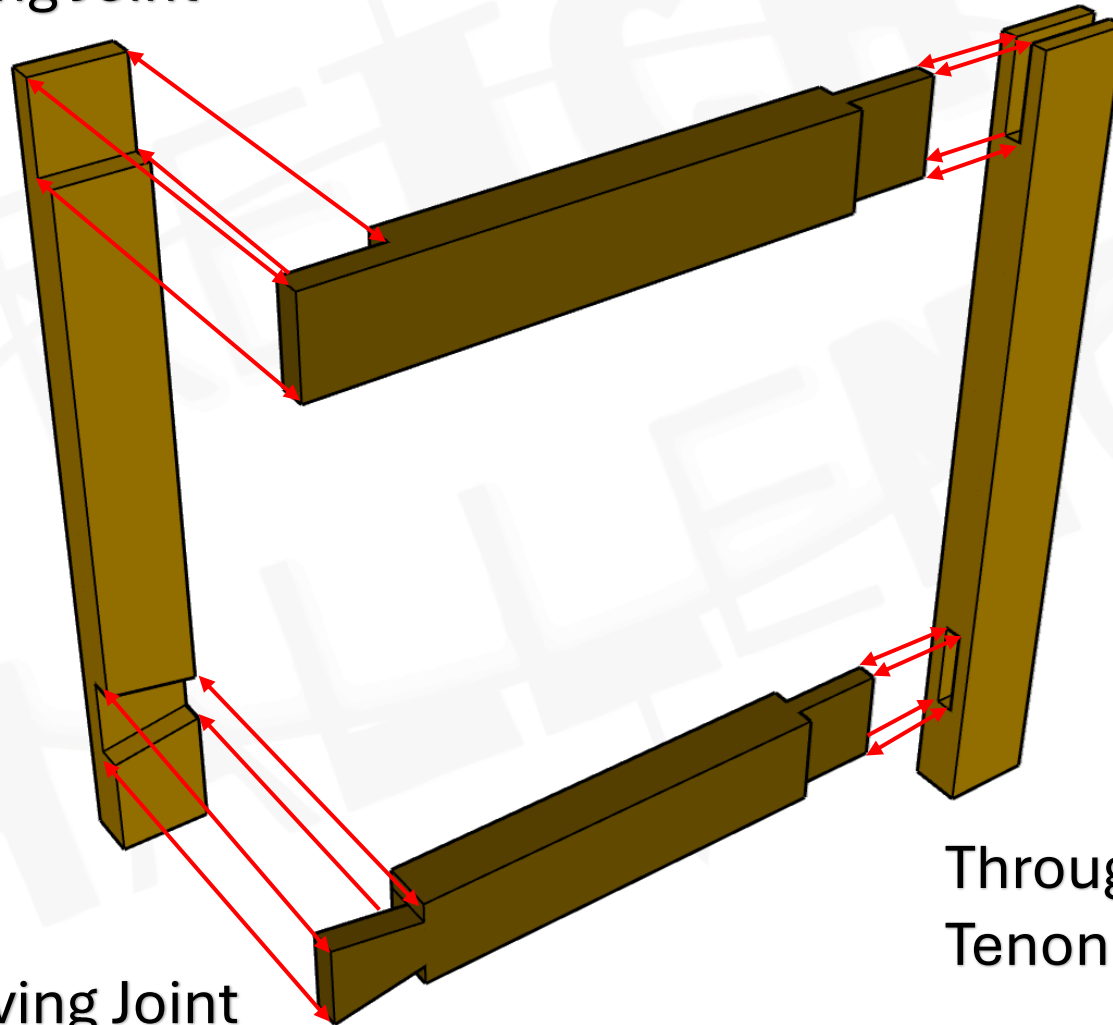

Dovetail Halving Joint

Through Mortice & Tenon Joint

Overall Dimensions:

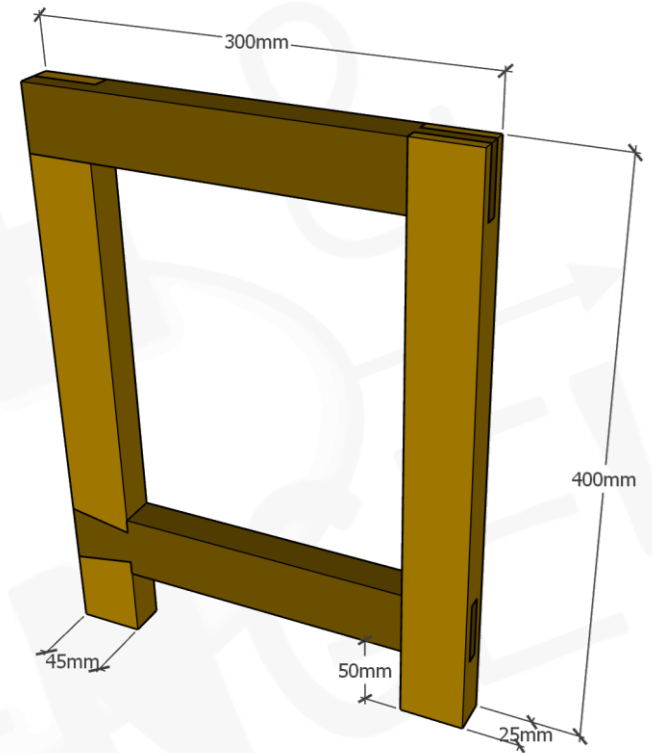
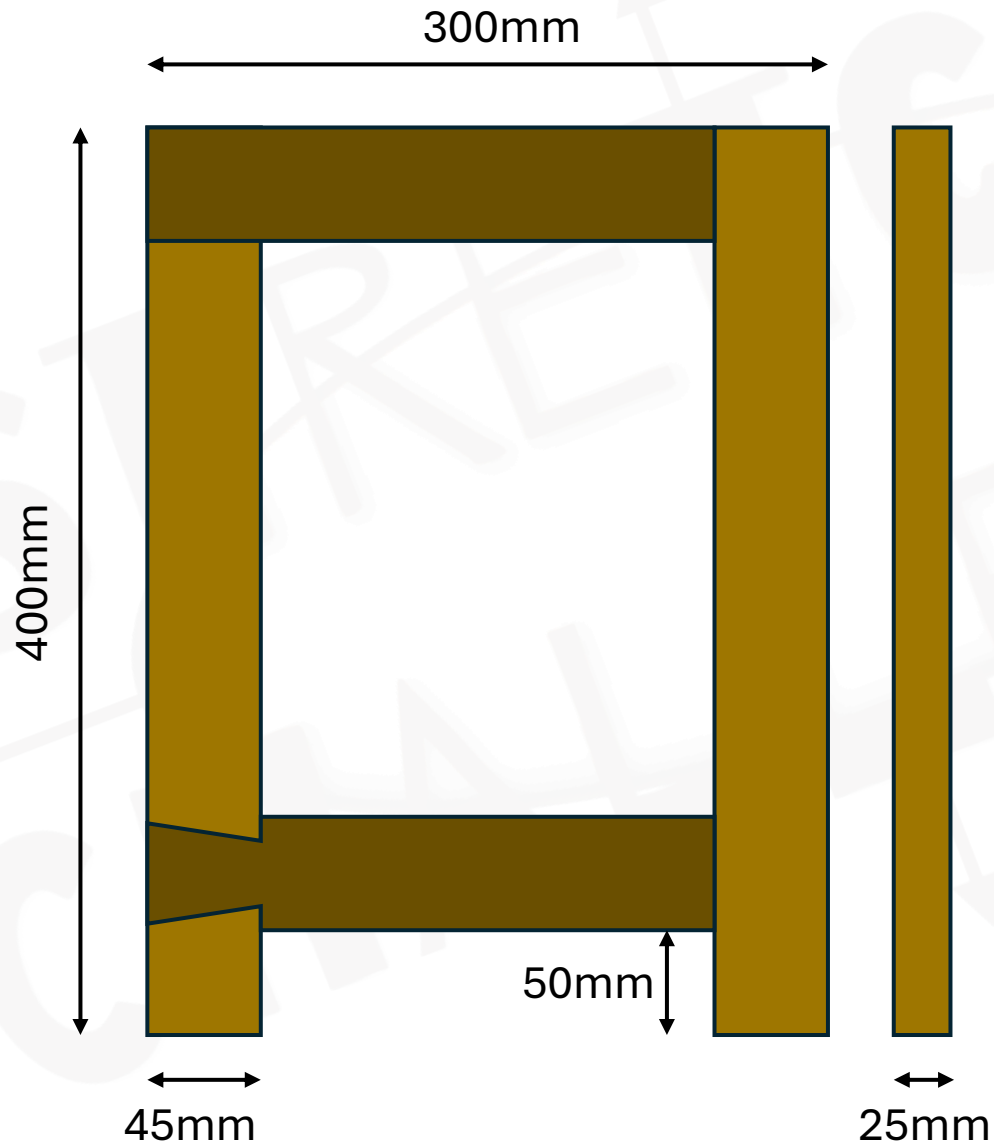

Corner Halving Joint.

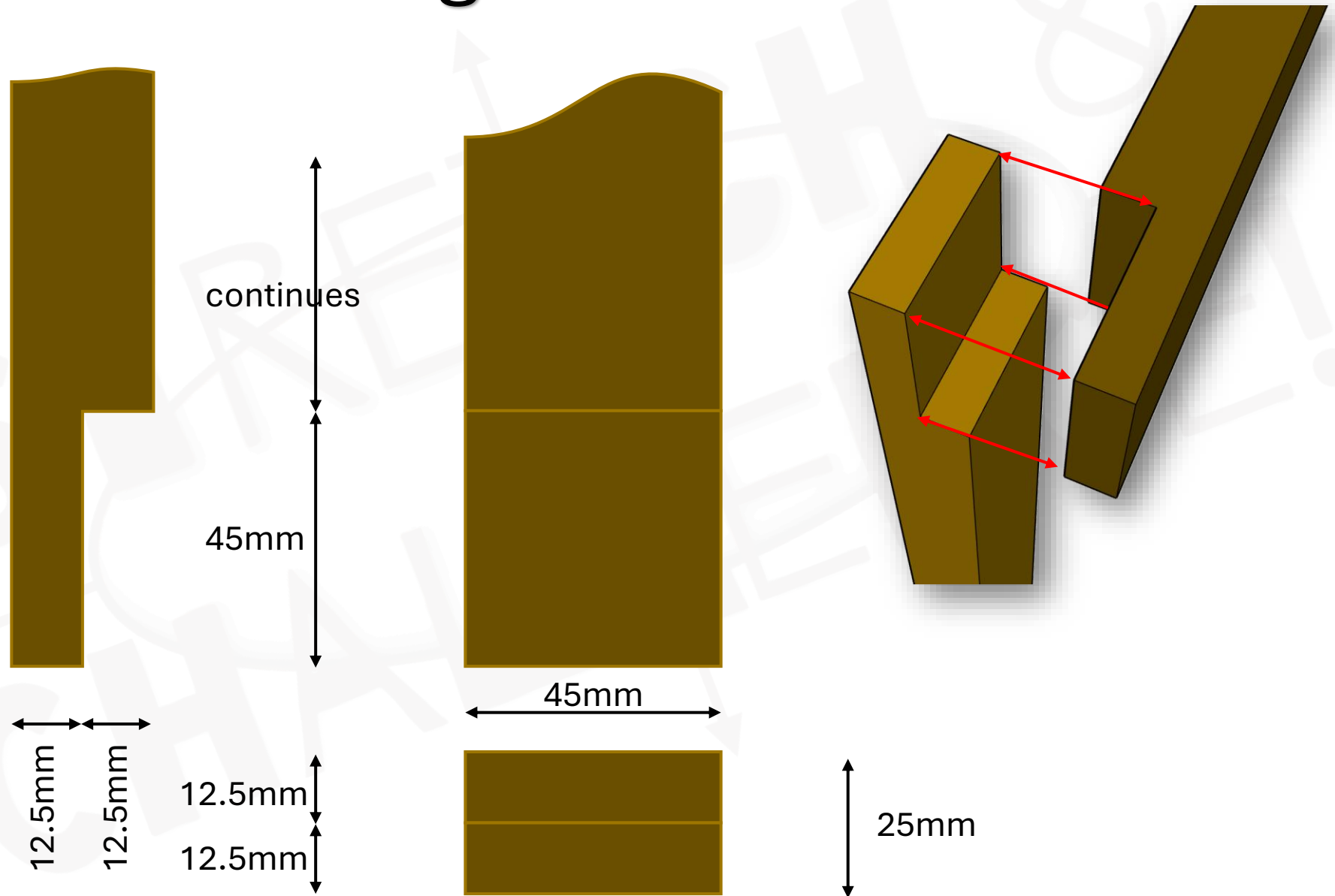

Corner Bridle Joint.

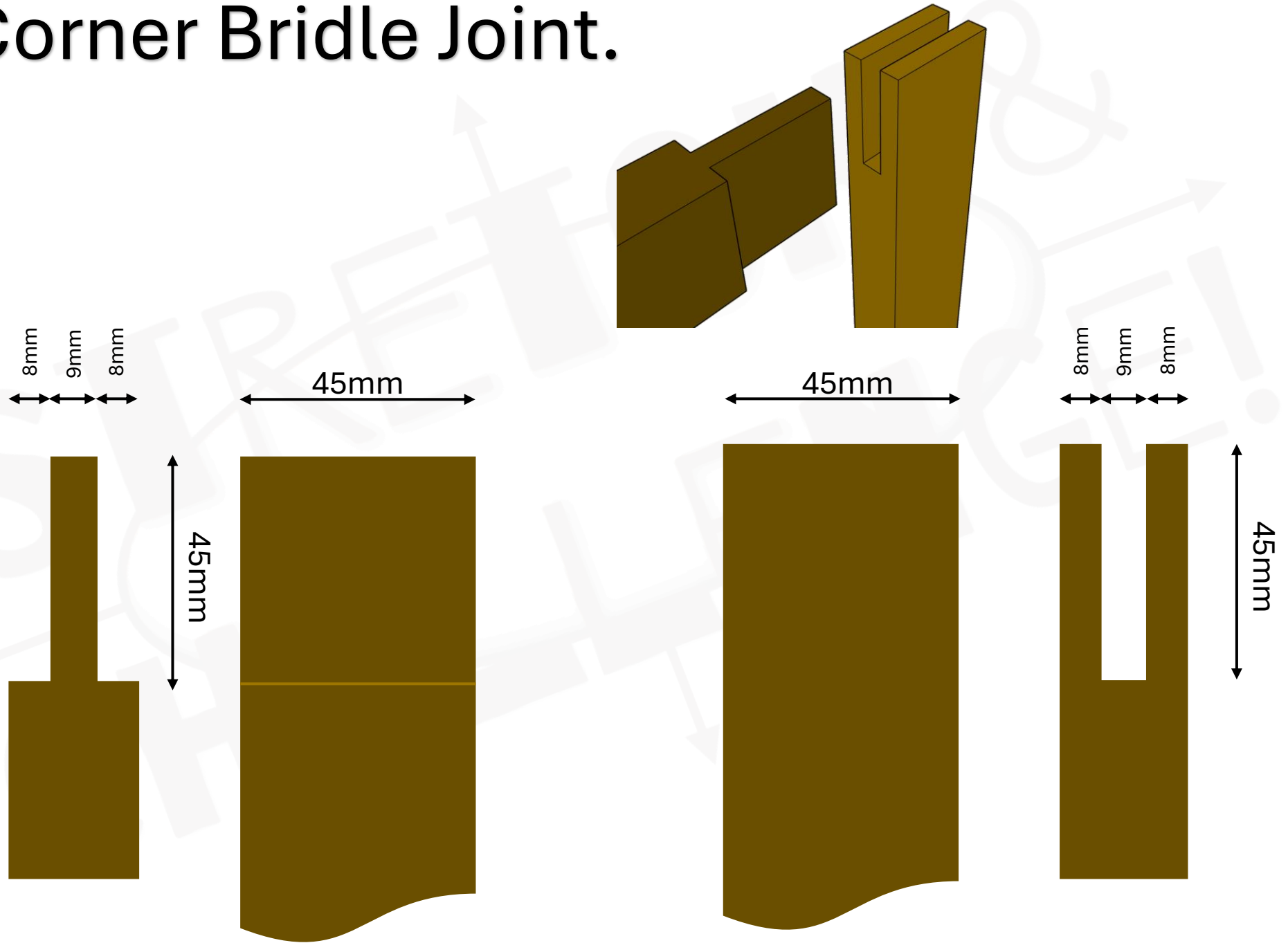

Through Mortice & Tenon Joint.

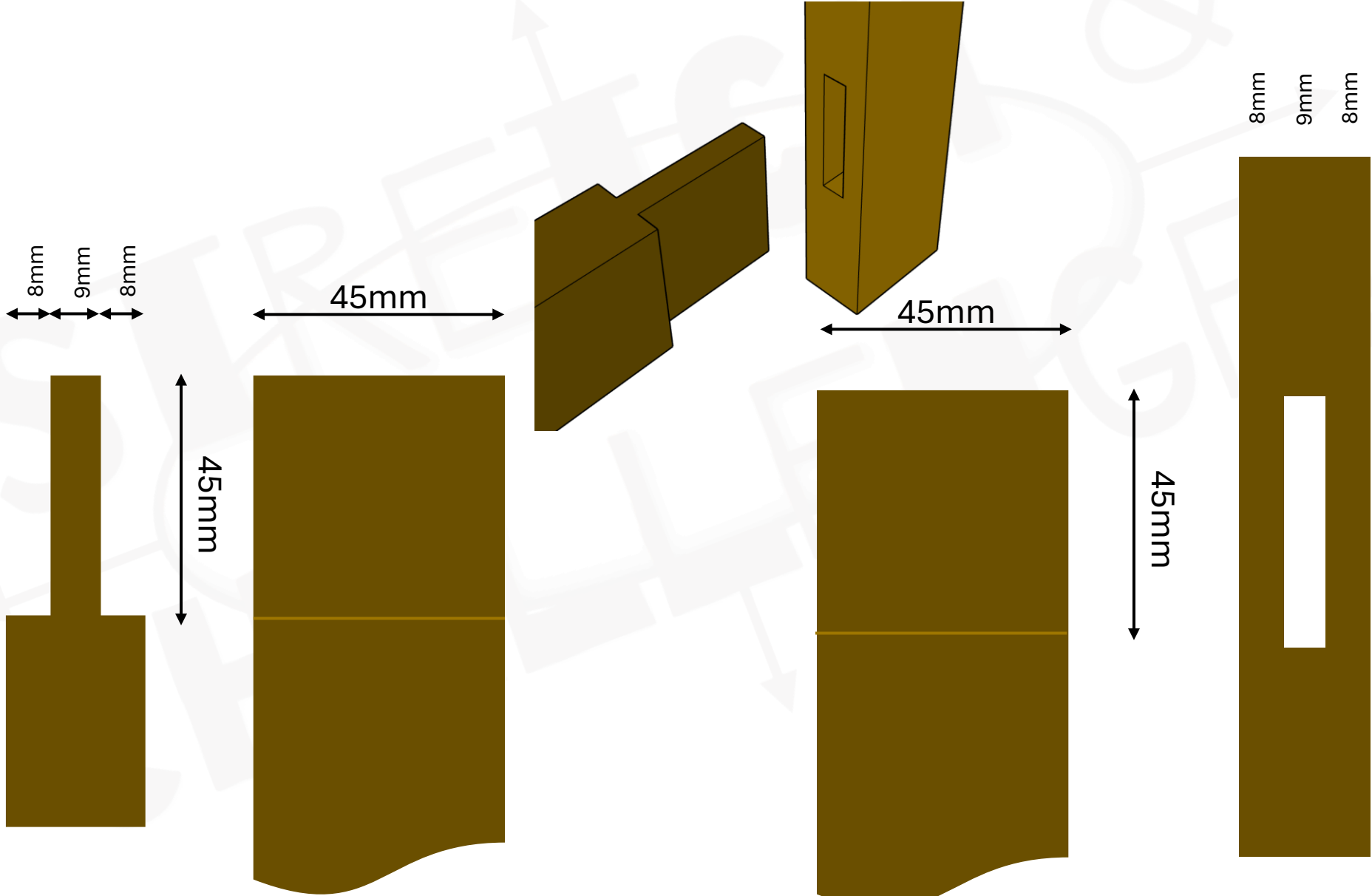

Dovetail Halving Joint.

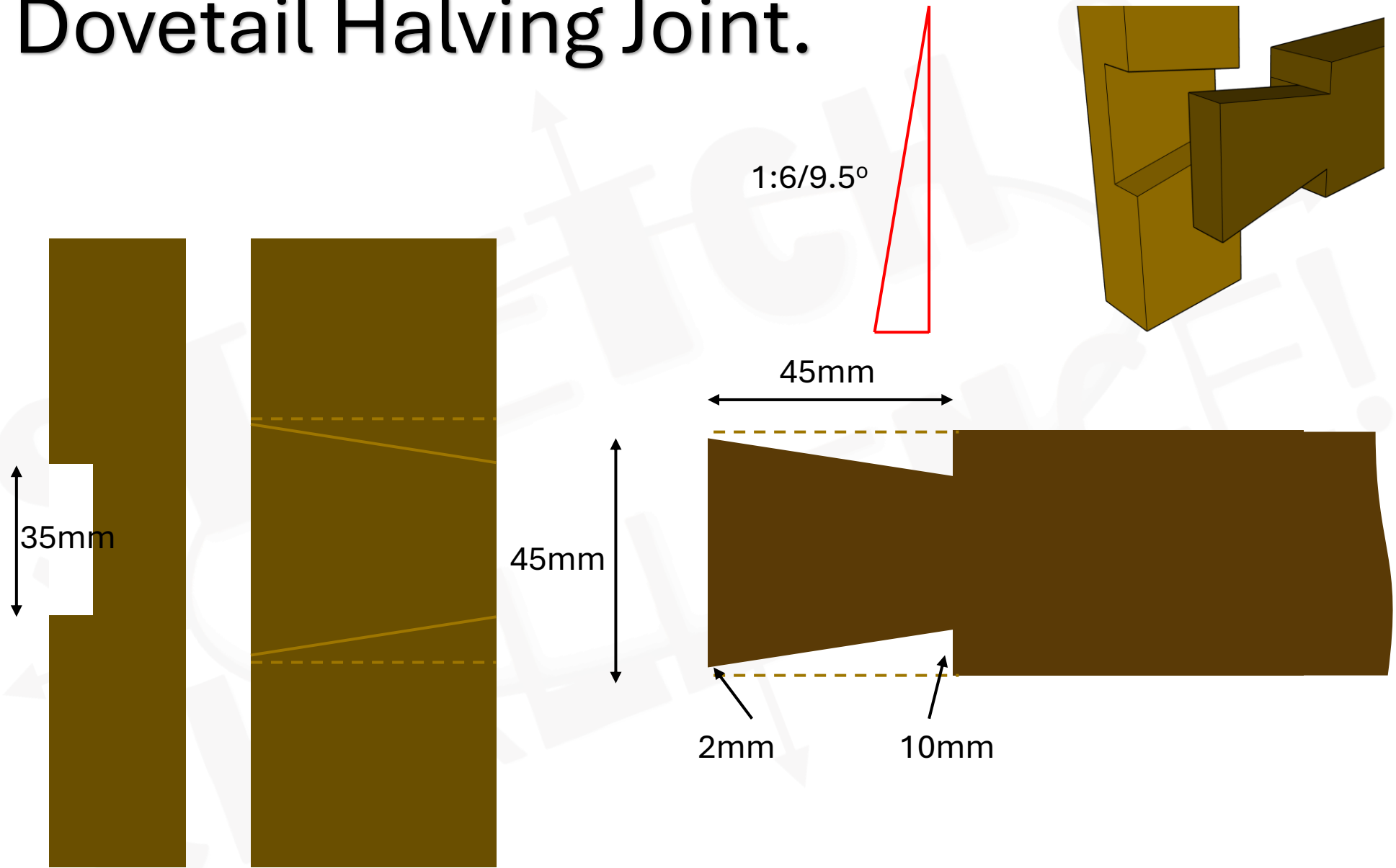

**STRETCH &
CHALLENGE!**

**Student Workbook
S&C001: 4 Joint Relay Frame**

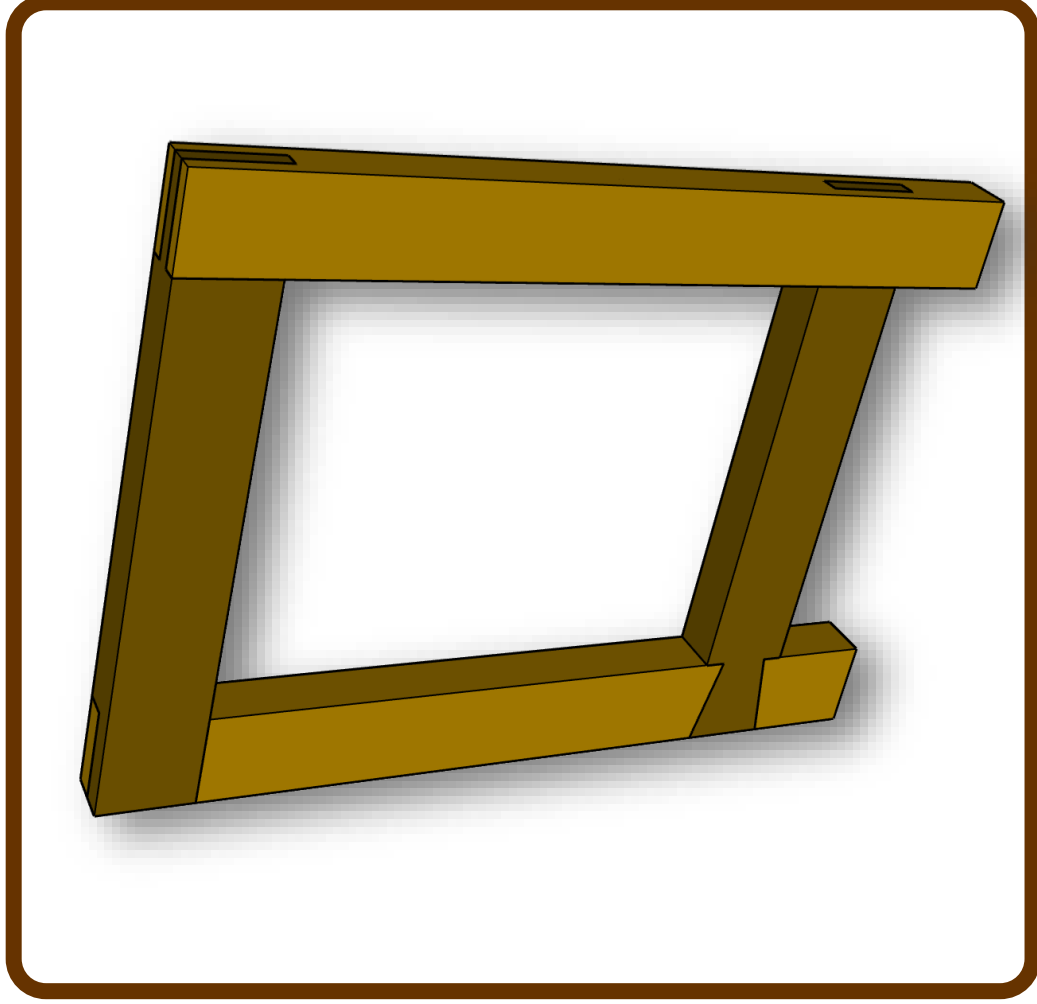

Lecturer:
James Rix

THE TEAM:

Team Name:

Members:

Team Captain:

Team Assignments:

Students must stick to this order and be responsible for the joint.

No.	Task	Responsible
1	Corner Halving Joint	
2	Corner Bridle Joint	
3	Through Mortice & Tenon Joint	
4	Dovetail Halving Joint	

CUTTING LIST:

Component	Length	Width	Thick
Left Stile			
Right Stile			
Top Rail			
Bottom Rail			

HOW MANY RUNNING METERS?

How many running meters of the stock size 45mmx25mm will be required for the whole job?, remember to add for waste and kerf cuts. In the box below show how you worked it out.

STUDENT FEEDBACK:

How many reps did you do?

Student	Reps

Student Comments: